



# THE MISSING INGREDIENT

A survey report on the quality of fly ash  
bricks in Delhi-NCR





# THE MISSING INGREDIENT

A survey report on the quality of fly ash  
bricks in Delhi-NCR

**Research direction:** Chandra Bhushan

**Expert advice:** Dr D.D. Basu and Nivrit Kumar Yadav

**Author:** Ishita Garg

**Research support:** Parth Kumar and Juhi Purwar

**Editor:** Arif Ayaz Parrey

**Design and cover:** Ajit Bajaj

**Photographs:** Juhi Purwar

**Production:** Rakesh Shrivastava and Gundhar Das

**Advisor:** Soumen Maity (Development Alternatives)



CSE is grateful to Shakti Sustainable Energy Foundation for their support. Shakti Sustainable Energy Foundation works to strengthen the energy security of the country by aiding the design and implementation of policies that encourage energy efficiency, renewable energy and sustainable transport solutions, with an emphasis on sub-sectors with the most energy saving potential. Working together with policy makers, civil society, academia, industry and other partners, the Foundation takes concerted action to help chart out a sustainable energy future for India ([www.shaktifoundation.in](http://www.shaktifoundation.in)).

**Disclaimer:** The views and analysis expressed in this report do not necessarily reflect the views of Shakti Sustainable Energy Foundation. The Foundation also does not guarantee the accuracy of any data included in this publication nor does it accept any responsibility for the consequences of its use.



© 2019 Centre for Science and Environment

For private circulation only.

Material from this publication can be used, but with acknowledgement.

**Citation:** Ishita Garg 2019, *The Missing Ingredient: A survey report on the quality of fly ash bricks in Delhi-NCR*, Centre for Science and Environment, New Delhi

*Published by*

**Centre for Science and Environment**

41, Tughlakabad Institutional Area, New Delhi 110 062

**Phones:** 91-11-40616000

**Fax:** 91-11-29955879

**E-mail:** [cse@cseindia.org](mailto:cse@cseindia.org)

**Website:** [www.cseindia.org](http://www.cseindia.org)

# Contents

<b>1. Introduction</b>	<b>7</b>
Methodology	8
<b>2. Fly ash bricks</b>	<b>10</b>
Raw materials	10
Raw material proportion	12
Manufacturing process	13
<b>3. Results and analysis</b>	<b>15</b>
Composition	15
Characteristics	17
Result analysis	19
State-level analysis	20
<b>4. Conclusion and recommendations</b>	<b>23</b>
Recommendations	24
<b><i>Annexures</i></b>	<b>26</b>
<b><i>References</i></b>	<b>38</b>



# 1 Introduction

Mushrooming population and improvements in standard of living have burgeoned demand for bricks. Traditionally, this demand was met by clay-fired bricks, but there is a growing understanding that clay bricks are harmful for the environment, because they use fertile top soil and the process of manufacturing also causes air pollution. Fly ash bricks are a worthy substitute, because they make use of material which is otherwise considered waste.

If official policies and notifications are any indication, the government seems to agree, as there is a favourable regime to promote the use of fly ash as a resource material. However, despite official support and promotion, uptake of fly ash bricks has not been as widespread as one would expect.

The Central Electricity Authority (CEA) publishes an annual report on fly ash generation at coal- and lignite-based thermal power plants and its utilization. According to CEA's 2017–18 report,<sup>1</sup> the overall utilization of fly ash has increased rapidly from 9.2 million tonne per annum (MTPA) in 1998–99 to 131.8 MTPA in 2017–18, whereas the uptake of fly ash in bricks, blocks, and tiles has increased from 0.7 MTPA in 1998–99 to 17.69 MTPA in 2017–18 (see *Graph 1: Fly ash generation and utilization in the last two decades*).

It is evident from the CEA report that the percentage of overall utilization of fly ash compared to its generation has increased approximately five times in the



Juhi Purwar

**Stacks of green fly ash bricks:** Fly ash bricks are a viable alternative to clay-fired bricks, as waste material (fly ash) from thermal power plants (and other industries like beer factories) is their primary ingredient

**Graph 1: Fly ash generation and utilization in the last two decades**

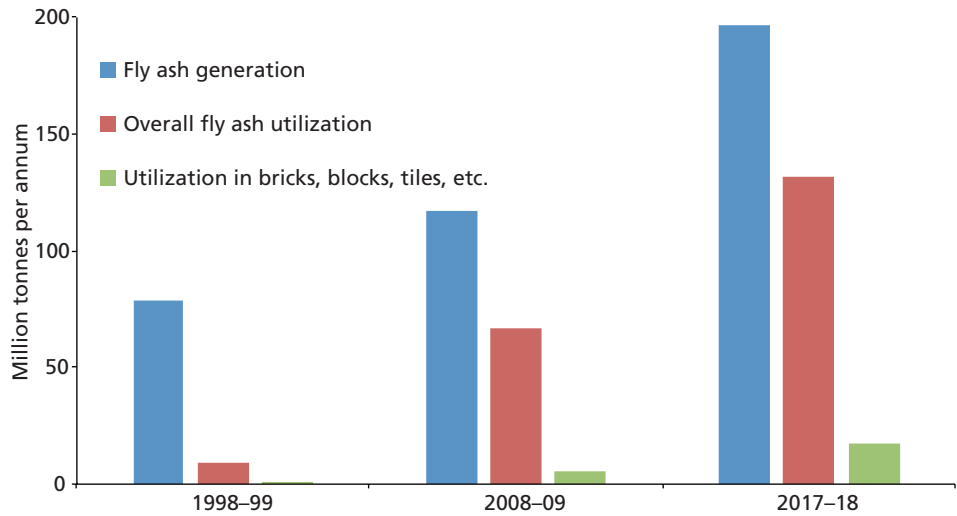

Source: Report on fly ash generation at coal- or lignite-based thermal power plants and its utilization in the country for the year, 2017-18, Central Electricity Authority

last two decades, whereas the uptake in bricks and blocks has still not gained much traction. Fly ash utilization in bricks was 8 per cent in 1998-99, which could only climb up to 13 per cent in 2017-18.

In order to understand the cause of this slow uptake of fly ash in the brick sector, Centre for Science and Environment (CSE) contacted various stakeholders, including individual house owners, small and large builders, and officials from government departments.

The main reasons, based on the feedback of various stakeholders, were:

1. Skepticism about the quality of fly ash bricks being manufactured
2. The issue of marketing (through dealers and distributors). Clay-fired bricks are easily available almost everywhere. Fly ash bricks, on the other hand, are usually unavailable in the nearest building material store. This limits access to fly ash bricks.

To examine the issue of quality of fly ash bricks in detail, CSE decided to conduct a study in Delhi-NCR. Brick samples from 51 fly ash making units in 11 districts were collected and tested for various parameters (see *Annexure 4*).

**Methodology**

A large number of small-scale fly ash units are functional in Delhi-NCR, but information regarding the exact number of such units is not available with state Pollution Control Boards (SPCBs) of Haryana, Rajasthan and Uttar Pradesh and the Delhi Pollution Control Committee (DPCC). At the start of the study, CSE had information about a hundred fly ash brick manufacturing units in Delhi-NCR registered with the Fly Ash Brick Manufacturers Association (FBMA). Using this base information, CSE commenced the study and collected 51 samples from different manufacturing units from 11 districts (in Delhi, Haryana, Rajasthan and Uttar Pradesh) that come under Delhi-NCR (see *Map 1: Sampling locations* and *Graph 2: State-wise distribution of samples*). During the survey, CSE found that the number of operating fly ash brick units is far greater than the registered number. Three samples were taken from construction sites

**Map 1: Sampling locations**

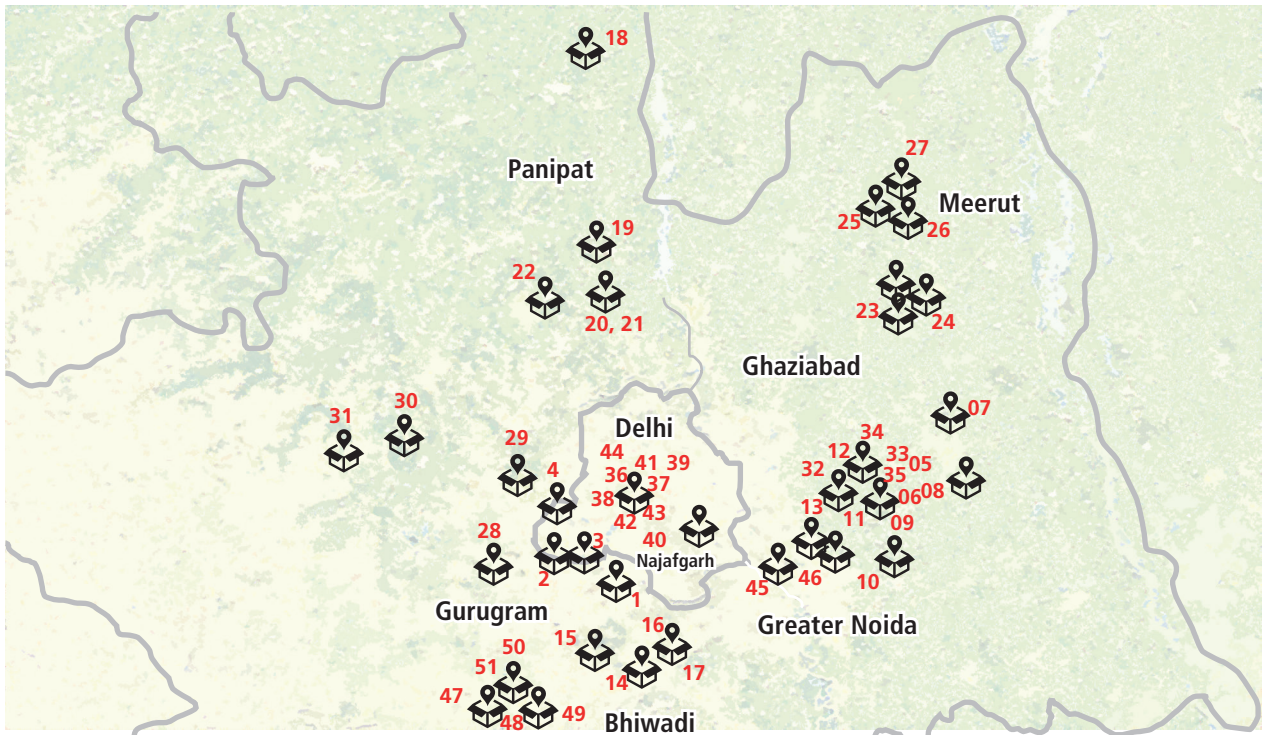

Source: CSE survey

**Graph 2: State-wise distribution of samples**

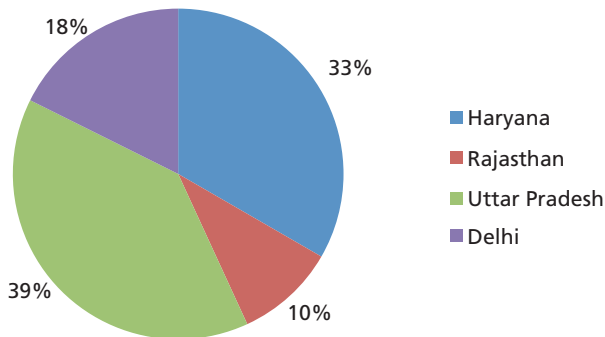

Source: CSE survey

to evaluate the quality of the bricks used in construction. Out of the other 48 samples collected, only 22 per cent were from units registered with FBMA.

The standard procedure for sampling as given in IS 5454:1979 (first revision) was followed for the process.

Sampled bricks were tested in Delhi Technical University (DTU) for three parameters, viz. compressive strength, water absorption capacity and efflorescence. All the bricks tested were more than 30 days old. The methodology adopted for testing the above parameters is as per IS 3495 (Part 1–3): 1992 and IS 12894: 2002 and is detailed out in *Annexure 1*. The study aims to find characteristics and composition and any co-relation between them.

## 2 Fly ash bricks

In the presence of moisture, fly ash reacts with lime at ordinary temperatures and forms a compound having cementitious properties. The reaction produces calcium silicate hydrates, which give strength to fly ash–lime in the form of bricks and blocks.<sup>2</sup> Generally, constituents like silica, alumina and iron oxide in the composition of fly ash are responsible for its pozzolanic properties, as lime reacts with these oxides to develop different lime-bearing hydrated phases.<sup>3</sup> The chemical equation of the reaction is:

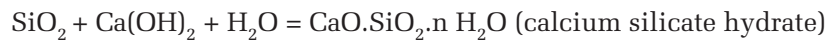

### Raw materials

#### Fly ash

Indian standard pulverized fuel ash (PFA, i.e. fly ash, bottom ash, pond ash or mound ash) has two categories:

1. Siliceous PFA normally produced by the burning of anthracite or bituminous coal. It contains less than 10 per cent by mass of reactive calcium oxide.



Juhi Purwar

**Making fly ash bricks:** Fly ash reacts with lime at ordinary temperatures and forms a compound having cementitious properties

2. Calcareous PFA normally produced by the burning of lignite or sub-bituminous coal. It contains more than 10 per cent by mass of reactive calcium oxide.

As the name itself suggests, fly ash constitutes a major portion (60–80 per cent) of fly ash bricks. Most properties of the final product, therefore, are dependent on the fly ash used. In a mixture, fly ash works in three ways:

1. The reactive portion of fly ash undergoes a pozzolanic reaction and contributes to hydrated mineralogy, matrix formation and progressive strength enhancement.
2. The inert coarse portion of fly ash acts as a micro-aggregate and helps in sizing down pores.
3. The superfine inert portion of fly ash gives a packing effect to fill sub-micropores and densify the matrix.<sup>4</sup>

A coal-based thermal power station may produce the following four kinds of ash:

**Fly ash:** This kind of ash is extracted from flue gases in a dry form through electrostatic precipitators (ESP). It is fine in nature and possesses good pozzolanic properties.

**Bottom ash:** This ash is collected at the bottom of boiler furnaces. It is comparatively coarser than ESP ash, with high unburnt carbon content. Bottom ash is inert compared to fly ash.

**Pond ash:** When fly ash or bottom ash or both are mixed together in any proportion with a large quantity of water to form a slurry and deposited in ponds wherein water gets drained away, the deposited ash is called pond ash.

**Mound ash:** Fly ash or bottom ash or both mixed in any proportion and deposited in dry form in the shape of a mound is termed as mound ash.

Bureau of Indian Standards' IS: 3812 (Part-1) (that sets the standards for the chemical and physical requirements of fly ash bricks) terms all these types of ash as PFA. Generally, only fly ash collected from first and second field of ESP (with the finest particles) meets the requirements set under the standards. Use of pond ash in brick making should be avoided. It does not react uniformly with lime and is not suitable for building materials. Pond or mound ash in which bottom ash has not been mixed can be used for making bricks after testing and trials.<sup>5</sup>

### Sand and stone dust

Sand is used as filler in fly ash–lime compacts. It occupies interstitial positions in the cement hydrates formed as a result of the chemical interaction between fly ash and lime, making the cement network rigid and mechanically more stable. The surface of the sand particles also can undergo reaction with the lime, resulting in the formation of a small quantity of calcium silicate that improves the interfacial bonding between the hydrated cementitious phase and the sand filler.<sup>6</sup>

### Lime

Lime must always be used in the form of calcium hydroxide  $[\text{Ca}(\text{OH})_2]$  with a minimum of 85 per cent purity. Wet sludge should never be allowed to dry up, lest the same get carbonized, proving useless in cement reactions. If quick lime

(CaO) needs to be used, it should be slaked for three–four days and only the resultant paste should be used. Heat of hydration of quick lime causes cracking in the product. Pebbles and lime that has not reacted needs to be segregated and thrown out before using the slaked lime.<sup>7</sup>

### Gypsum

Gypsum is added to the fly ash–lime mixture to render early strength to bricks. Two types of gypsum can be used for making fly ash bricks, chemical gypsum and mineral gypsum. Gypsum should be around 60 per cent pure (as specified in IS: 1288: 1982) and lump-free. Mineral gypsum has less purity compared to chemical gypsum; therefore, the amount of gypsum in the mixture should be adjusted accordingly to obtain the desired quality of bricks.

Plaster of Paris (POP) is an alternative to gypsum used in the fly ash brick manufacturing industry. While the strength of fly ash bricks that contain POP is yet to be validated, manufacturers claim that in winters POP fly ash bricks dry faster and attain better strength compared to bricks containing gypsum.

### Cement

Cement is an alternative to gypsum and lime in fly ash bricks. It is generally a preferred additive due to ease of mixing and wide availability.

### Raw material proportion

Fly ash bricks are prepared using different combinations and proportions of the aforementioned raw materials. Proportioning depends on the quality of raw material and on the required compressive strength and water absorption capacity of the bricks. Some of the combinations commonly used for making fly ash bricks and the proportion of raw materials as suggested by National Thermal Power Corporation (NTPC) are provided as follows:<sup>8</sup>

#### Combination 1

Fly ash + Gypsum + Sludge lime + Sand or stone dust

Fly ash	: 55–60 per cent
Gypsum or phosphogypsum	: 5 per cent
Sludge lime	: 15–20 per cent
Sand or stone dust	: 20–25 per cent

#### Combination 2

Fly ash + Gypsum + Hydrated lime + Sand or stone dust

Fly ash	: 60–65 per cent
Gypsum	: 4 per cent
Hydrated lime	: 8–12 per cent
Sand or stone dust	: 18–27 per cent

#### Combination 3

Fly ash + Cement + Sand or stone dust

Fly ash	: 50–60 per cent
Cement	: 8–10 per cent
Sand or stone dust	: 32–40 per cent

These combinations generally produces brick of strength 7.5–10 N/mm<sup>2</sup>.

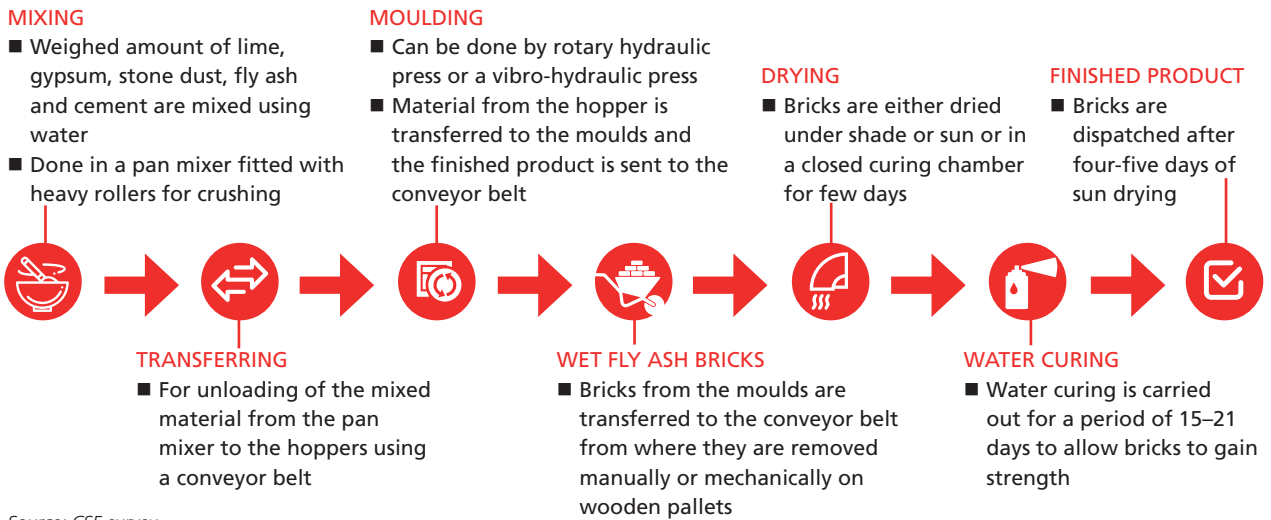
**Figure 1: Fly ash brick making process**

Source: CSE survey

## Manufacturing process

### Mixing

Raw materials are added to the pan mixer in an adequate ratio and mixed thoroughly with water until a homogeneous paste is formed. A pan mixer of adequate capacity should be used for thorough mixing and breaking up of lumps in lime and gypsum.

When sludge lime and gypsum are used as binding material, they should first be wet-grinded with water in the pan mixer until a homogeneous, lump-free paste is formed. The other raw materials—stone dust, fly ash and cement—should then be added with the required quantity of water and homogenized mixing should be carried out for three–five minutes until the mixture becomes uniform. In case hydrated lime and gypsum are used, the required quantity of sand or stone dust, gypsum, hydrated lime, and fly ash should initially be dry mixed, followed by addition of the required quantity of water to form a homogeneous paste. The same procedure is applicable when using cement as binding material in place of hydrated lime and gypsum or mixed with the two.

Small lumps of lime, if any, left in the mix can cause cracks in the bricks, lowering their overall strength. The reason for these cracks is the hydration of lime lumps after the curing period.

### Moulding

The homogeneous mixture prepared in a pan mixer is fed into the press for moulding into brick shape through a conveyer belt. Moulding of bricks is done by using two different types of techniques: hydraulic compaction and vibro-hydraulic compaction.

**Hydraulic press:** In this kind of presses, the mixture is compacted into brick shape through high hydraulic pressure. Pressure can be uniaxial or biaxial. Biaxial presses achieve better compaction. These presses have a manufacturing capacity of 2,000 to 1 lakh bricks per day. The mixture from the pan mixer is

## The ideal mixing sequence

### For Lime–gypsum combinations

Stone dust or sand is added to a rotating pan mixer. After a few seconds, lime is added in a slurry form. Once the sand and lime is homogenized into a smooth paste, gypsum is added. After the mixture attains a uniform colour and smoothness, fly ash is added to it. If needed, more water can be added as well. The consistency of the mixture is checked by the uniformity in colour and absence of any lumps. Its water content is checked by determining its ability to be forming it into a lump in one hand. If the lump is hard, the consistency is considered alright. However, if the lump is soft and breaks, more water should be added to the mixture.

Addition of water should always be done by sprinkling and not by pouring at one place. This improves mixing and reduces the time of mixing.

### For cement combinations

The process is similar to the one followed for lime–gypsum combinations. Sand or stone dust and cement are dry mixed first with no addition of water. Once uniformity of colour is obtained between sand and cement, fly ash is added. After the mixture attains uniformity in colour in the dry state, the desired quantity of water is sprinkled over the mix. The consistency of the mixture is checked by the uniformity in colour and absence of any lumps. Its water content is checked by determining its ability to be forming it into a lump in one hand. If the lump is hard, the consistency is considered alright. However, if the lump is soft and breaks, more water should be added to the mixture.

conveyed to these presses through a conveyer belt and bricks are taken out either manually or through the conveyer belt. These machines can be semi-automatic or fully automatic.

**Vibro-hydraulic press:** It works in the same manner as the hydraulic press, the only difference being the addition of a vibration table which facilitates the filling of raw material in the moulds with lesser space. Compaction efficiency is also better. However, in this case, the best quality is achieved if there is a gradation of sizes.

After removal from the conveyor belt, the moulded or green bricks are kept on a wooden pallet. The wooden pallet should be kept in a moist environment or in shade and not directly under the sun. After that, green bricks should be left for air drying for a period of time that varies with the season. In winters, due to high moisture content, dry curing should be carried out for 24–48 hours, while in summers, dry curing can be carried out only for about 24 hours.

### Curing and drying

After green bricks are air dried, they are arranged in stacks for curing. Curing is done on alternate days for a period of 20 days (for cement and lime combinations, the duration is of seven days). This can be done either manually or by mechanical means. In some cases, steam curing is done in covered chambers so that the heat released from the bricks (as a result of exothermic reaction) is trapped in the chambers and used for drying the bricks. Gunny bags or tarpaulin are used to cover the bricks after curing. Once cured, the bricks are again left to air dry for a few more days before being dispatched.

### 3 Results and analysis

#### Composition

Fly ash, the key component for fly ash bricks, is mainly sourced from thermal power plants. In some places, it is also obtained from other factories. In Haryana, units get fly ash from power plants such as CLP's Mahatma Gandhi Super Thermal Power Project at Jhajjar; NTPC, Jharli; NTPC Badarpur; Panipat Thermal power plant and other factories. In Uttar Pradesh, the only source of fly ash is NTPC, Dadri thermal power plant. For Delhi and Rajasthan, the source of fly ash is NTPC, Badarpur. The characteristics of fly ash may vary depending on the source and may play an important role in the quality of bricks. Unfortunately, the fact that all kinds of fly ash are not same is generally unrecognized, even by the thermal power plants.

Fly ash is mixed with different raw materials for manufacturing bricks. In the absence of a standard protocol on composition and proportion of different raw materials to be used, manufacturers resort to trial and error to improve the strength of the bricks. A decision regarding proportion of raw materials also depends on the cost and availability of different raw materials. For example,



Juhi Purwar

**A worker curing a stack of fly ash bricks: More than four-fifths of all the fly ash bricks tested under the survey were of poor quality**

the cost of stone dust in Rajasthan is around Rs 300–500 per tonne, whereas it costs upto Rs 1,000–1,500 tonne in Delhi, Haryana and Uttar Pradesh.

As discussed in the previous section, three compositions were recommended by NTPC to get good quality bricks. However, during the survey, CSE identified nine different compositions in the 51 samples collected (see *Table 1: Fly ash brick compositions*). The most popular compositions were discovered to be fly ash + lime + gypsum, also termed as FaL-G (composition Type 1); followed by a composition that added stone dust to FaL-G. The other compositions share the rest of the market almost equally (see *Graph 3: Relative popularity of different compositions*).

**Table 1: Fly ash brick compositions**

Type	Composition
C1	Ash* (70 per cent) + Lime (20 per cent) + Gypsum (10 per cent)
C2	Ash (50–70 per cent) + Lime (15–20 per cent) + Gypsum (5–10 per cent) + Stone dust (5–15 per cent)
C3	Ash (71 per cent) + Lime (18 per cent) + Gypsum (7 per cent) + Cement (4 per cent)
C4	Ash (70–80 per cent) + Cement (10–15 per cent) + Sand (15 per cent)
C5	Ash (50–60 per cent) + Lime (15–20 per cent) + Gypsum (15 per cent) + Sand (15 per cent)
C6	Ash (68 per cent) + Gypsum (6 per cent) + Cement (7 per cent) + Stone dust (19 per cent)
C7	Ash (40–60 per cent) + Cement (13 per cent) + Stone dust (25–50 per cent)
C8	Ash (90 per cent) + Cement (10 per cent)
C9	Ash (74 per cent) + Lime (13 per cent) + Gypsum (5 per cent) + Cement (3 per cent) + Dust (4 per cent)

\*Bottom ash, fly ash or pond ash or their mixture

Source: CSE survey

**Graph 3: Relative popularity of different compositions**

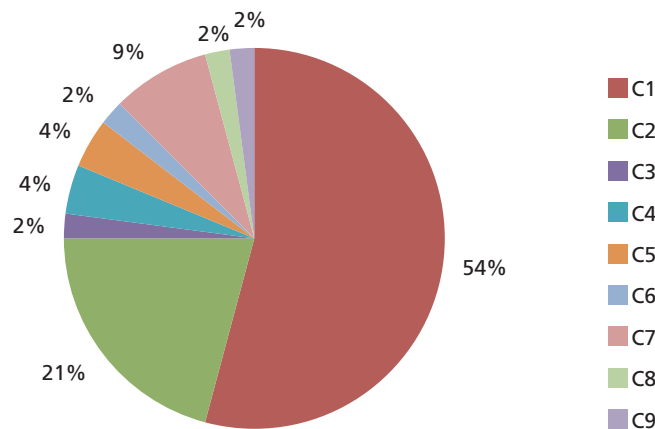

Source: CSE survey

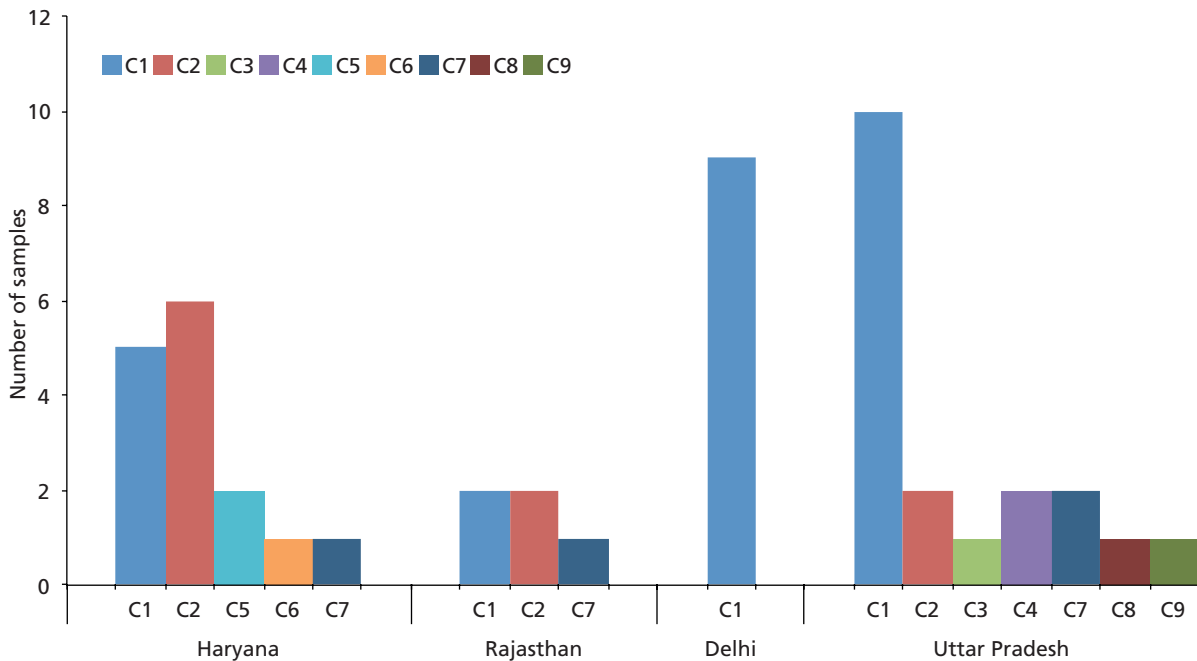
**Graph 4: State-wise variations in composition**

Source: CSE survey

A state-wise analysis of compositions reveals that in Delhi only the standard FaL-G composition (C1) is used to make bricks, whereas brick makers in Uttar Pradesh follow as many as seven different composition patterns, although C1 continues to dominate. In Haryana and Rajasthan, owing to availability of stone dust at a cheaper price, the formula of adding stone dust with lime and gypsum is quite popular and is practiced as much as the standard FaL-G composition pattern (see *Graph 4: State-wise variations in composition*).

Manufacturers use sand or stone dust as they claim that it helps to make the bricks stronger. The use of cement in bricks results in early setting and helps make the final bricks ready quicker. Some manufacturers prefer cement-based bricks over FaL-G bricks to save time. However, use of cement also raises the production cost. The market price of fly ash bricks is in the range of Rs 3,500–4,500 per 1,000 bricks, irrespective of composition. This prevents many manufacturers from using cement in their bricks to save money.

### Characteristics

Samples collected have been tested to analyze the quality of bricks in terms of compressive strength, water absorption capacity and efflorescence. According to IS 12894: 2002, standards for these parameters are as follows:

**Compressive strength:** The minimum average wet compressive strength of pulverized fuel ash-lime bricks cannot be less than what has been specified for each class.

**Water absorption capacity:** Bricks need to have an average water absorption capacity of not more than 20 per cent by mass upto Class 12.5 and 15 per cent by mass for higher classes.

**Efflorescence:** Bricks need to have not more than ‘moderate’ rating of efflorescence upto class 12.5 and ‘slight’ for higher classes.

IS 12894: 2002 classifies bricks into 10 different classes on the basis of strength. However, it does not specify the purpose for which the brick of a particular class should be used (see *Annexure 2*). Such a standard (specifying the purpose for which each class of bricks should be used) exists from clay bricks (IS 2212: 1991, see *Annexure 3*). In absence of any similar standard for fly ash bricks, it is assumed that the standard for clay bricks can be extended to fly ash bricks.

According to the standard, only bricks with strength of 7.5 and 12.5 N/mm<sup>2</sup> can be used for construction purposes (see *Table 2: Brick selection for different construction purposes*).

**Significance of tested parameters**

- Compressive strength: To determine the load carrying capacity of bricks under compression.
- Water absorption: To determine power of the bricks to absorb water. Low water absorption means less dampness in walls.
- Efflorescence: It is directly proportional to water absorption. The process involves dissolution of internal salts in water. Water containing the salts flows to the surface and is evaporated, leaving a coating of the salts behind. Low efflorescence indicates the presence of lesser quantity of salts on the surface.

**Table 2: Brick selection for different construction purposes**

Purpose	Class of bricks that can used (N/mm <sup>2</sup> )	Remarks
Facing	12.5	Bricks shall be free from minor defects such as chips at the edge of corners. Colour and texture may also be specified if so required
Plinths and foundations below damp-proof course—ground well drained and no chance of continual wetting in foundations	12.5 or 7.5	
Plinths and foundations below damp-proof course—sub-soil water table at a high level	12.5 or 7.5	Bricks shall be free from efflorescence. They shall also not have any salt content that will affect the mortar of the masonry. Bricks may preferably be the densest available with minimum water absorption capacity
External walls, neither plastered nor rendered on the outer face	12.5	Bricks shall preferably be of uniform colour. Exposed joints shall be pointed with a dense water tight mortar
External walls finished on both faces with a water-tight plaster or rendering	7.5 or better quality common bricks	For situation exposed to severe weather only Class 12.5 bricks shall be used
Internal walls	7.5	Class 3.5 bricks also may be considered for use, provided they satisfy the requirements for strength (as per IS 1077:1991). For walls that are liable to be frequently in contact with water such as in bathrooms, only Class 7.5 or better bricks shall be used
Free standing walls and parapets	12.5	A dense water-tight mortar shall be used for masonry. Parapets shall preferably be finished on all sides with a water tight plaster

Source: IS 2212:1991, p 5

**Table 3: Different categories for compressive strength and water absorption capacity**

Category	Compressive strength (N/mm <sup>2</sup> )	Water absorption capacity (per cent mass)
Category 1 (Desired)	= > 7.5	< = 20
Category 2 (Average)	= > 7.5	> 20
Category 3 (Poor)	< 7.5	< = 20
Category 4 (Unacceptable)	< 7.5	> 20

Source: CSE survey

Some research papers suggest that fly ash bricks of strength 7.5 N/mm<sup>2</sup> are optimum for most architectural structures.<sup>9</sup> But this requirement varies with different government and private construction agencies. For example, according to Delhi Schedule of Rates (DSR), 2018 and Analysis of Rates for Delhi (DAR), 2016, both published by Central Public Works Department (CPWD), ‘fly ash bricks used in structures above plinth-level upto the fifth floor level should be of class designation 10 as per IS: 12894, with an average comprehensive strength of 10 N/mm<sup>2</sup>.’

### Result analysis

Test results revealed that while efflorescence fluctuated between ‘nil’ and ‘moderate’, thus largely remaining within limits, a huge variation was observed with respect to comprehensive strength and water absorption capacity. Comprehensive strength of bricks from all states surveyed ranged between 4–11 N/mm<sup>2</sup>, and water absorption capacity stood at 10–29 per cent by mass.

A comparison has been made between the wide variations in parameters with the requirement under the CPWD documents as well as IS 2212: 1991 (as they have different criteria).

### Comparison with IS 2212: 1991

Samples were divided into four categories ranging from the desired to unacceptable quality on the basis of their compressive strength and water absorption capacity to perform a combinatorial analysis (see *Table 3: Different categories for comprehensive strength and water absorption capacity*). The categorization was done considering 7.5 N/mm<sup>2</sup> as the minimum required strength and 20 per cent water absorption capacity by mass as the maximum. The analysis produced the following results:

- 84 per cent samples failed to conform to the minimum requirement of 7.5 N/mm<sup>2</sup> compressive strength.
- 27 per cent samples fall under category 4 having compressive strength less than 7.5 N/mm<sup>2</sup> and water absorption more than 20 per cent. As the name suggests, these bricks are not acceptable for any type of construction purpose.
- Only 12 per cent samples met the criteria of desired bricks (see *Graph 5: Combinatorial analysis of compressive strength and water absorption capacity*).
- When samples were analyzed for strength of 12.5 N/mm<sup>2</sup>, none of the samples met the criteria. As per IS 2212: 1991, only bricks with a strength of 12.5 N/mm<sup>2</sup> may be used in parapets and facing walls. Since none of the samples met this criterion, fly ash bricks of what strength are being used in these structures?

**Graph 5: Combinatorial analysis of compressive strength and water absorption capacity**

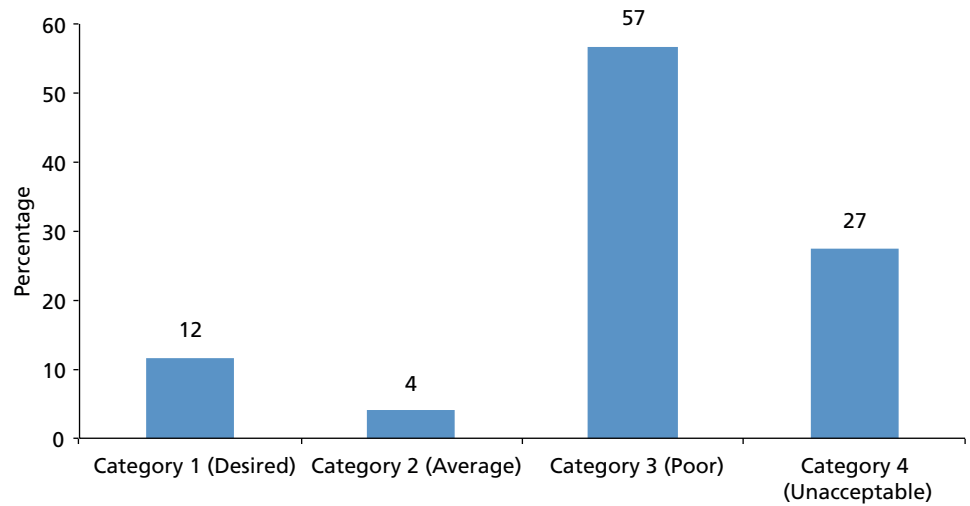

Source: CSE survey

**Comparison with CPWD standards**

CPWD’s DAR mentions strength of 10 N/mm<sup>2</sup> without any differentiation on the basis of purpose for which the bricks are intended. On analyzing samples, only one sample met this criterion. Given the fact that CPWD’s specifications are widely followed for construction purposes throughout the country, the question begging to be asked is how bricks with strength less than what CPWD recommends are being manufactured and consumed in the market.

**State-level analysis**

Analyzing brick strength of 7.5 N/mm<sup>2</sup> state-wise, Haryana and Uttar Pradesh turn out to be producing the maximum number of poor quality bricks (53 per cent and 50 per cent respectively). Although some samples from Rajasthan and Delhi also fall under the poor category, no samples from these two states fall under category 4. In fact, they contribute 40 per cent and 22 per cent samples of desired quality bricks. The big find has been that most bricks produced in all the four states fall under the poor quality category (see *Graph 6: State-wise variations in the quality of bricks*). This actually means that the entire construction in the NCR region is made with poor or sub-standard quality materials.

The reason behind the wide variation in the strength and water absorption capacity and the production of lower number of desirable samples is not clear. An effort was made to find co-relations, if any, between the characteristics and composition of brick, resulting in the following observations:

- The standard composition of fly ash, gypsum and lime results in bricks of both maximum (11 N/mm<sup>2</sup>) and minimum strength (4.9 N /mm<sup>2</sup>), the percentage of each raw material remaining unchanged.
- Similarly, the same composition gives minimum water absorption capacity of 10 per cent and maximum water absorption capacity of 29 per cent as well. This composition, with addition of stone dust, also gives a high water absorption capacity of 29 per cent.
- The standard composition, when used with sand, gives strength of 7.5 N/

**Graph 6: State-wise variations in the quality of bricks**

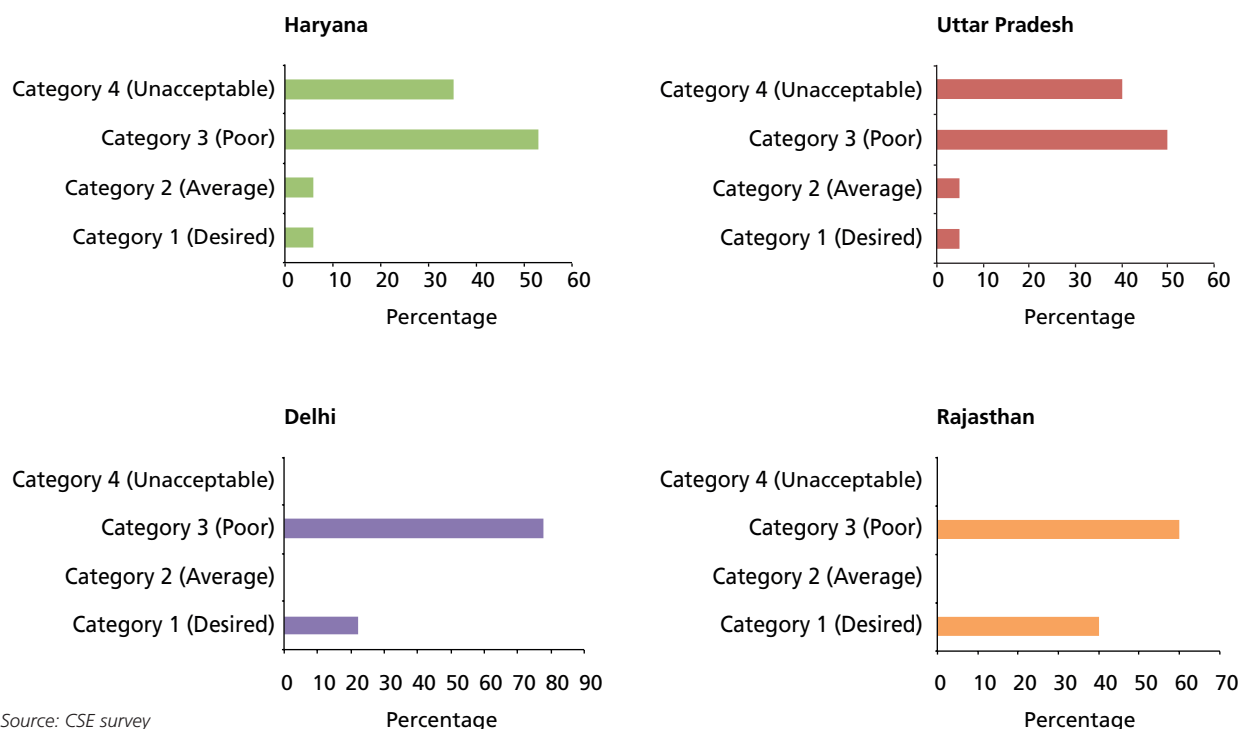

Source: CSE survey

### Fly ash bricks at construction sites

Three samples were collected from multi-storey building construction sites to check the quality of bricks being used. Samples were collected from:

1. AIIMS, Jhajjar constructed by Shapoorji Pallonji
2. EMAAR's Gurgaon Greens (residential), Gurugram by JMC Projects India Ltd
3. Miglani Bally Hai (residential), Greater Noida by Miglani Groups

Testing results of these sites shows that bricks used at all three sites fall under the worst category. These bricks did not even conform to the minimum requirement of 7.5 N/mm<sup>2</sup>. They are, therefore, a long way from meeting CPWD's criterion.

Site	Compressive strength (N/mm <sup>2</sup> )	Water absorption (per cent mass)
1	5.9	29
2	5.6	29
3	6.3	21

mm<sup>2</sup> and 7.9 N/mm<sup>2</sup> respectively (in the two samples tested under this section).

- The highest number of bricks produced with C1 composition is of poor quality. Desired quality bricks are comparatively less in number. It is pertinent to mention that this composition has the largest number of samples.
- C2 composition shows a similar trend.
- All bricks manufactured using cement with any composition resulted in poor quality bricks.
- Addition of sand to the standard composition (C1) improved the percentage of good quality of bricks (see *Graph 7: Correlation between composition and characteristics of bricks*).

**Graph 7: Co-relation between composition and characteristics of bricks**

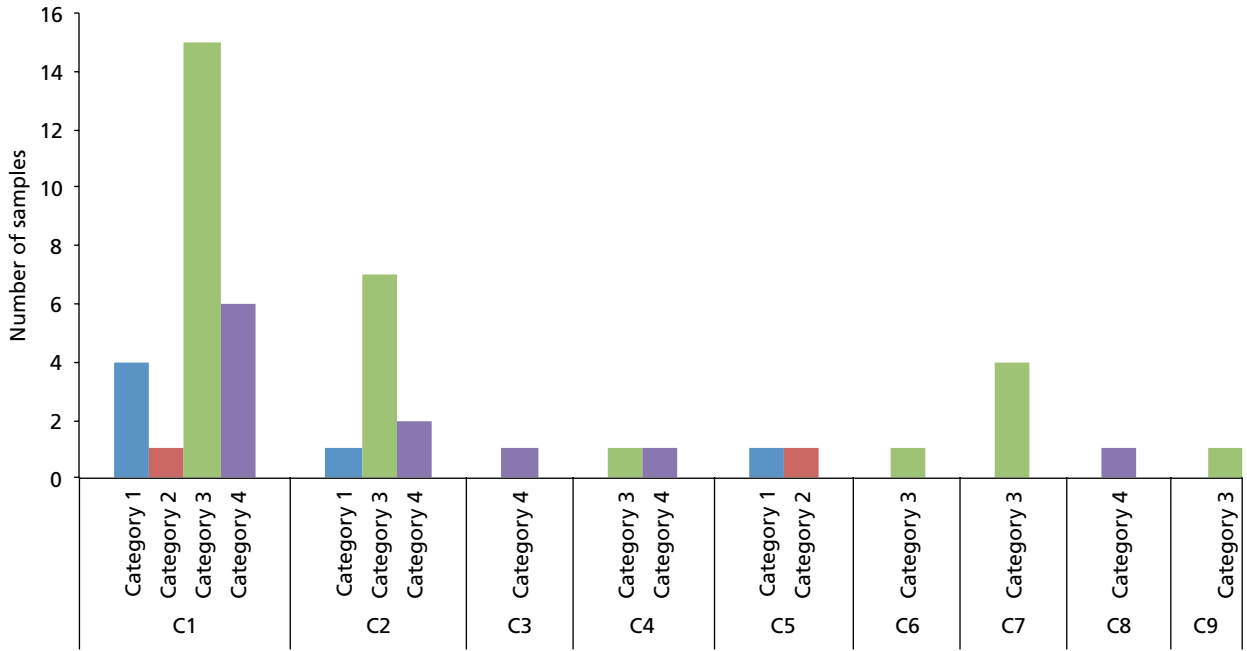

Source: CSE survey

No strong co-relation was established between composition and quality of bricks as it was observed that the same composition produces bricks of varying quality. Most bricks fell in C3 (the category with strength of less than 7.5 N/mm<sup>2</sup> and water absorption capacity less than or equal to 20 per cent by mass), it indicates that manufacturers are able to attain the desired water absorption capacity but more focus is needed to produce bricks of desired strength.

## 4 Conclusion and recommendations

The use of fly ash bricks is rising in India's construction industry. Concerns about the quality of fly ash bricks are also lengthening. Despite availability of a variety of machines in the market, the quality of the bricks produced is not always satisfactory. In some cases, the blame for the poor quality falls on the brick manufacturers. In an attempt to make a quick buck, quality of the additive (lime, gypsum or cement) is compromised. However, in most cases, the reason for the poor quality of fly ash bricks is lack of technical knowledge, starting from the choice of raw materials, to the composition selection, the mixing process and even the curing method. It has been observed that proper mixing and curing substantially improve brick quality but this important fact remains unknown to many manufacturers.

The findings of this survey report further legitimize the seriousness of these concerns. CSE collected 51 samples and the fact that almost none of them met the desired quality standards is telling. This study revealed that the same composition can produce different qualities of bricks with varying



Juhi Purwar

**Stacks of fly ash bricks ready to be transported (background):** Lack of technical knowledge is a primary factor for the poor quality of fly ash bricks produced in the selected states

comprehensive strength and water absorption capacity. From this it can be inferred that composition is not the only major factor in determining the quality of bricks. The reason for the poor quality can, thus, be attributed to issues related to the manufacturing process. In this section, we discuss some of these issues and possible solutions to them.

**1. Quality of fly ash used:** A majority of manufacturers in the sampled area use pond ash or bottom ash instead of fly ash as their major raw material. This contradicts expert opinion that both these kinds of ash are not suitable for brick making owing to their poor reactivity. Pond ash contains fly ash mixed with bottom ash which dilutes the quality of fly ash drastically, rendering it non-reactive. On the other hand, bottom ash is constituted of agglomerated granules of various crystalline products with no reactivity. Alkalis from coal become volatile at high temperatures, form agglomerates and settle along with bottom ash. These alkalis react with water and have a deleterious effect on brick quality, causing efflorescence in the finished product.

If use of pond ash cannot be avoided, experts recommend that coarser particles should be segregated using air classifiers and the finer fraction could be used; but that would incur additional costs. Alternatively, a higher dose of cement can be mixed in to offset the weakness of pond ash.

**2. Improper mixing of raw materials:** This is the most important yet forgotten part of the manufacturing process. Raw materials, especially lime, if not mixed thoroughly, may leave lumps in the raw material mixture. This lumpy mixture, when packed into bricks, causes cracking of bricks on curing.

**3. Incomplete curing:** Fly ash brick manufacturing process requires at least 28 days of curing at the end of the manufacturing process to attain maximum strength. This significant stage of the process is often ignored by manufacturers due to high demand in the market. Often, demand-side stakeholders are also not aware of the importance of this step and they push manufacturers to deliver bricks quickly, even before the curing period gets over.

**4. Poor maintenance of presses:** Raw material mixture is transferred to moulds and is converted to brick by compacting through presses. These presses apply a specific amount of pressure on bricks depending on the number of moulds in the machine. For example, an approximate pressure of 25–30 tonnes (approximately 250–300 kN) is applied on each brick to get a good compaction. However, if not maintained properly, the presses become inefficient and the pressure they put on bricks is reduced over time. Additionally, some material gets stuck inside the moulds, resulting in improper shaping of bricks. Therefore, regular cleaning of moulds is necessary.

**5. Lack of technical knowledge:** The foundational problem is lack of technical knowledge among manufacturers regarding the manufacturing process of fly ash bricks. The choice and quantity of raw materials to be added is decided on the basis of guidance of labourers who have worked in a similar unit previously. This knowledge is purely experiential, not imbued with scientific understanding or the varying quantities of raw materials used in different areas.

### Recommendations

Results display non-compliance with IS 2212: 1992 (that provides a classification of bricks on the basis of use). CPWD requirements are also not being followed by manufacturers. Therefore, guidelines or a standard should be set up clearly

laying down the required quality of bricks (with regard to compressive strength and water absorption capacity) for different purposes. Strict implementation of such guidelines or standard must be ascertained.

In view of these lacunae, CSE makes the following recommendations:

- Quality control systems need to be set for fly ash bricks. For this purpose, a study should be undertaken to check what quality of fly ash is being used by brick makers.
- Use of pond ash and bottom ash should be stopped in fly ash brick manufacturing.
- Entrepreneurs, workers and supervisors should be trained with a view of building their capacity and improving their technical knowledge vis-à-vis the process of manufacturing good quality fly ash bricks. Efficient training manuals in local languages and extensive training programmes should be designed for entrepreneurs and workers. Demonstrations of model brick making units and processes should be the integral part of such trainings.
- Entrepreneurs should be made aware that quality bricks can be made at affordable prices. The only requirement is to follow basic technical guidelines.
- Consumers should be made aware about the quality of fly ash bricks and the need to bring fly ash brick industry under the consumer redress system.
- Manuals for quality control should be designed and circulated among entrepreneurs.
- A rating system for fly ash bricks should be designed by private or public agencies and made public.
- In addition to promotion of fly ash bricks, government should also promote other products made of fly ash like tiles, aggregates, etc.

# Indian Standard

## METHODS OF TESTS OF BURNT CLAY BUILDING BRICKS

### PART 1 DETERMINATION OF COMPRESSIVE STRENGTH

#### ( Third Revision )

#### 1 SCOPE

1.1 This standard ( Part 1 ) covers the method of determination of compressive strength of burnt clay building bricks.

#### 2 REFERENCE

2.1 The Indian Standard IS 5454 : 1976 'Method for sampling of clay building bricks ( first revision )' is a necessary adjunct to this standard.

#### 3 GENERAL

3.1 The dimensions shall be measured to the nearest 1 mm.

3.2 All apparatus and testing equipment shall be calibrated at frequent intervals.

3.3 The number of specimens for the test shall be selected according to IS 5454 : 1976.

#### 4 METHODS

##### 4.1 For Solid Bricks

###### 4.1.1 Apparatus

A compression testing machine, the compression plate of which shall have a ball seating in the form of portion of a sphere the centre of which coincides with the centre of the plate, shall be used.

###### 4.1.2 Preconditioning

Remove unevenness observed in the bed faces to provide two smooth and parallel faces by grinding. Immerse in water at room temperature for 24 hours. Remove the specimen and drain out any surplus moisture at room temperature. Fill the frog ( where provided ) and all voids in the bed face flush with cement mortar ( 1 cement, clean coarse sand of grade 3 mm and down ). Store under the damp jute bags for 24 hours followed by immersion in clean water for 3 days. Remove, and wipe out any traces of moisture.

###### 4.1.3 Procedure

Place the specimen with flat faces horizontal, and mortar filled face facing upwards between two 3-ply plywood sheets each of 3 mm thickness and carefully centred between plates of the testing machine. Apply load axially at a uniform rate of 14 N/mm<sup>2</sup> ( 140 kgf/cm<sup>2</sup> ) per minute till failure occurs and note the maximum load at failure. The load at failure shall be the maximum load at which the specimen fails to produce any

further increase in the indicator reading on the testing machine.

NOTE — In place of plywood sheets plaster of Paris may be used to ensure a uniform surface for application of load.

###### 4.1.4 Report

The report shall be as given below:

$$\text{Compressive strength in N/mm}^2 \text{ (kgf/cm}^2\text{)} = \frac{\text{Maximum load at failure in N (kgf)}}{\text{Average area of the bed faces in mm}^2 \text{ (cm}^2\text{)}}$$

4.1.4.1 The average of results shall be reported.

##### 4.2 For Perforated Bricks

###### 4.2.1 Apparatus

See 4.1.1.

###### 4.2.2 Preconditioning

Immerse the specimen in water at room temperature for 24 hours. Remove the specimen from water and drain out any surplus water. No mortar shall be filled in perforations and no mortar capping shall be provided.

###### 4.2.3 Procedure

Place the perforated faces of the brick between two 3-ply plywood sheets each of 3 mm thickness and carefully centred between the plates of the testing machine. Apply the load axially at uniform rate of 14 N/mm<sup>2</sup> ( 140 kgf/cm<sup>2</sup> ) per minute till the failure occurs and note the maximum load at failure. The load at failure shall be the maximum load at which the specimen fails to produce any further increase in the indicator reading on the testing machine.

NOTE — In place of plywood sheets plaster of Paris may be used to ensure a uniform surface for application of load.

###### 4.2.4 Report

The report shall be as given below:

$$\text{Compressive strength in N/mm}^2 \text{ (kgf/cm}^2\text{)} = \frac{\text{Maximum load at failure in N (kgf)}}{\text{Average net area of the two faces under compression in mm}^2 \text{ (cm}^2\text{)}}$$

4.2.4.1 The average of results shall be reported.

IS 3495 ( Part 2 ) : 1992

*Indian Standard*  
**METHODS OF TESTS OF BURNT CLAY  
 BUILDING BRICKS**

**PART 2 DETERMINATION OF WATER ABSORPTION**

*( Third Revision )*

**1 SCOPE**

1.1 This standard ( Part 2 ) covers the method of determination of water absorption of burnt clay building bricks.

**2 REFERENCE**

2.1 The Indian Standard IS 5454 : 1976 'Method for sampling of clay building bricks (*first revision*)' is a necessary adjunct to this standard.

**3 GENERAL**

3.1 The dimension shall be measured to the nearest 1 mm.

3.2 All apparatus and testing equipment shall be calibrated at frequent intervals.

3.3 The number of specimens for the test shall be selected according to IS 5454 : 1976.

**4 METHODS****4.1 24-hour Immersion Cold Water Test****4.1.1 Apparatus**

A sensitive balance capable of weighing within 0.1 percent of the mass of the specimen; and a ventilated oven.

**4.1.2 Preconditioning**

Dry the specimen in a ventilated oven at a temperature of 105 to 115°C till it attains substantially constant mass. Cool the specimen to room temperature and obtain its weight ( $M_1$ ). Specimen warm to touch shall not be used for the purpose.

**4.1.3 Procedure**

Immerse completely dried specimen in clean water at a temperature of  $27 \pm 2^\circ\text{C}$  for 24 hours. Remove the specimen and wipe out any traces of water with a damp cloth and weigh the specimen. Complete the weighing 3 minutes after the specimen has been removed from water ( $M_2$ ).

4.1.4 Water absorption, percent by mass, after 24-hour immersion in cold water is given by the following formula:

$$\frac{M_2 - M_1}{M_1} \times 100$$

# *Indian Standard*

## METHODS OF TESTS OF BURNT CLAY BUILDING BRICKS

### PART 3 DETERMINATION OF EFFLORESCENCE

#### ( *Third Revision* )

#### 1 SCOPE

1.1 This standard ( Part 3 ) covers the method of determination of efflorescence of burnt clay building bricks.

#### 2 REFERENCE

2.1 The Indian Standard IS 5454 : 1976 'Method for sampling of clay building bricks ( *first revision* )' is a necessary adjunct to this standard.

#### 3 GENERAL

3.1 The dimensions shall be measured to the nearest 1 mm.

3.2 All apparatus and testing equipment shall be calibrated at frequent intervals.

3.3 The number of specimens for the test shall be selected according to IS 5454 : 1976.

#### 4 METHOD

##### 4.1 Apparatus

A shallow flat bottom dish containing sufficient distilled water to completely saturate the specimens. The dish shall be made of glass, porcelain or glazed stoneware and of size 180 mm × 180 mm × 40 mm depth for square shaped and 200 mm dia × 40 mm depth for cylindrical shaped.

##### 4.2 Procedure

Place the end of the bricks in the dish, the depth of immersion in water being 25 mm. Place the

whole arrangement in a warm ( for example, 20 to 30°C ) well ventilated room until all the water in the dish is absorbed by the specimens, and the surplus water evaporates. Cover the dish containing the brick with suitable glass cylinder so that excessive evaporation from the dish may not occur. When the water has been absorbed and bricks appear to be dry, place a similar quantity of water in the dish and allow it to evaporate as before. Examine the bricks for efflorescence after the second evaporation and report the results.

##### 4.3 Report

The liability to efflorescence shall be reported as 'nil', 'slight', 'moderate', 'heavy' or 'serious' in accordance with the following definitions:

- a) *Nil* — When there is no perceptible deposit of efflorescence.
- b) *Slight* — When not more than 10 percent of the exposed area of the brick is covered with a thin deposit of salts.
- c) *Moderate* — When there is a heavier deposit than under 'slight' and covering up to 50 percent of the exposed area of the brick surface but unaccompanied by powdering or flaking of the surface.
- d) *Heavy* — When there is a heavy deposit of salts covering 50 percent or more of the exposed area of the brick surface but unaccompanied by powdering or flaking of the surface.
- e) *Serious* — When there is a heavy deposit of salts accompanied by powdering and/or flaking of the exposed surfaces.

*Indian Standard*  
**PULVERIZED FUEL ASH-LIME  
 BRICKS — SPECIFICATION**  
*( First Revision )*

**1 SCOPE**

This standard lays down the requirements for classification, general quality, dimensions and physical requirements of pulverized fuel ash-lime bricks used in buildings.

NOTE — Pulverized fuel ash-lime bricks having wet compressive strength less than 30 N/mm<sup>2</sup> approximately 300 kgf/cm<sup>2</sup> are covered in this standard and for higher strength ( see IS 2180 and IS 1077 ).

**2 REFERENCES**

The following Indian Standards contain provisions which, through reference in this text, constitute provision of this standard. At the time of publication, the editions indicated were valid. All standards are subject to revision and parties to agreements based on this standard are encouraged to investigate the possibility of applying the most recent editions of the standards indicated below :

IS No.	Title
712 : 1984	Specification for building limes ( <i>third revision</i> )
1727 : 1967	Methods of test for pozzolanic materials ( <i>first revision</i> )
3495	Methods of tests of burnt clay building bricks:
( Part 1 ) : 1992	Determination of compressive strength ( <i>second revision</i> )
( Part 2 ) : 1992	Determination of water absorption ( <i>second revision</i> )

IS No.	Title
( Part 3 ) : 1992	Determination of efflorescence ( <i>second revision</i> )
3812 : 1981	Specification for fly ash for use as pozzolana and admixture ( <i>first revision</i> )
4139 : 1989	Specification for calcium silicate bricks ( <i>second revision</i> )
5454 : 1978	Methods for sampling of clay burnt building bricks ( <i>first revision</i> )

**3 GENERAL REQUIREMENTS**

**3.1** Visually the bricks shall be sound, compact and uniform in shape. The bricks shall be free from visible cracks, warpage and organic matters.

**3.2** The bricks shall be solid and with or without frog 10 to 20 mm deep on one of its flat side. The shape and size of the frog shall conform to either Fig. 1A or Fig. 1B.

**3.3** In case of non-modular size of bricks, frog dimensions shall be the same as for modular size bricks.

**3.4** Hand-moulded bricks of 90 mm or 70 mm height shall be moulded with a frog 10 to 20 mm deep on one of its flat sides; the shape and size of the frog shall conform to either Fig. 1A or Fig. 1B ( see 5.1.1 for L, W and H ). Bricks of 40 or 30 mm height as well as those made by extrusion process may not be provided with frogs.

**3.5** The bricks shall have smooth rectangular faces with sharp corners and shall be uniform in shape and colour.

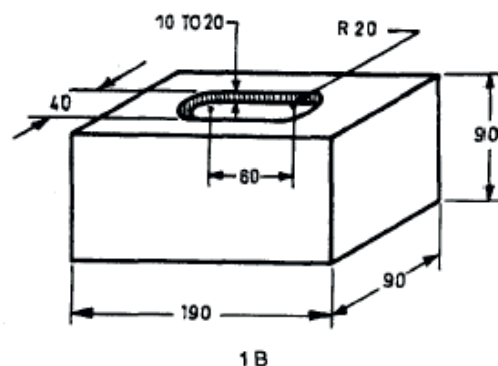
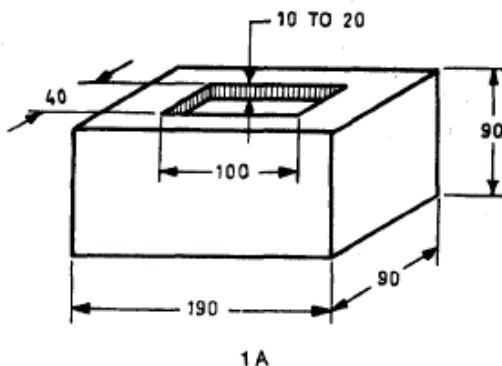

All dimensions in millimetres.

## IS 12894 : 2002

## 4 CLASSIFICATION

4.1 Pulverized fuel ash-lime bricks shall be classified on the basis of average wet compressive strength as given in Table 1.

**Table 1 Classes of Pulverized Fuel Ash-Lime Bricks**

Class Designation	Average Wet Compressive Strength not Less Than	
	N/mm <sup>2</sup>	kgf/cm <sup>2</sup> (Approx)
(1)	(2)	(3)
30	30.0	(300)
25	25.0	(250)
20	20.0	(200)
17.5	17.5	(175)
15	15.0	(150)
12.5	12.5	(125)
10	10.0	(100)
7.5	7.5	(75)
5	5.0	(50)
3.5	3.5	(35)

## 5 DIMENSIONS AND TOLERANCES

## 5.1 Dimensions

5.1.1 The standard modular sizes of pulverized fuel ash-lime bricks shall be as follows (see Fig. 1A and 1B):

Length (L)	Width (W)	Height (H)
mm	mm	mm
190	90	90
190	90	40

5.1.2 The following non-modular sizes of the bricks may also be used (see Fig. 1A and Fig. 1B):

Length (L)	Width (W)	Height (H)
mm	mm	mm
230	110	70
230	110	30

5.1.2.1 For obtaining proper bond arrangement and modular dimensions for the brickwork, with the non-modular sizes, the following sizes of the bricks may also be used:

Length (L)	Width (W)	Height (H)
mm	mm	mm
70	110	70 <sup>1</sup> / <sub>3</sub> length brick
230	50	70 <sup>1</sup> / <sub>2</sub> width brick

## 5.2 Tolerances

The dimensions of bricks when tested in accordance with 5.2.1 shall be within the following limits per 20 bricks:

## a) For Modular Size

Length 3 720 to 3 880 mm (3 800 ± 80 mm)

Width 1 760 to 1 840 mm (1 800 ± 40 mm)

Height 1 760 to 1 840 mm (1 800 ± 40 mm)

(For 90 mm high bricks)

760 to 840 mm (800 ± 40 mm)

(For 40 mm high bricks)

## b) For Non-modular Size

Length 4 520 to 4 680 mm (4 600 ± 80 mm)

Width 2 160 mm to 2 240 mm (2 200 ± 40 mm)

Height 1 360 mm to 1 440 mm (1 400 ± 40 mm)

(For 70 mm high bricks)

560 to 640 mm (600 ± 40 mm)

(For 30 mm high bricks)

5.2.1 Twenty (or more according to the size of stack) whole bricks shall be selected at random from the sample selected under 8. All blisters, loose particles of clay and small projections shall be removed. They shall then be arranged upon a level surface successively as indicated in Fig. 2A, 2B and 2C in contact with each other and in a straight line. The overall length of the assembled bricks shall be measured with a steel tape or other suitable inextensible measure sufficiently long to measure the whole row at one stretch. Measurement by repeated application of short rule or measure shall not be permitted. If, for any reason it is found impracticable to measure bricks in one row, the sample may be divided into rows of 10 bricks each which shall be measured separately to the nearest millimetre. All these dimensions shall be added together.

NOTE — By the agreement between the purchaser and the manufacturer pulverized fuel ash-lime bricks may be manufactured in other sizes also. The tolerance requirements of length, width and height shall remain the same as given above.

## 6 MATERIALS

## 6.1 Pulverized Fuel Ash (Commonly Known as Fly Ash)

Pulverized fuel ash commonly known as fly ash shall conform to Grade 1 or Grade 2 of IS 3812.

## 6.2 Bottom Ash

Bottom ash used as replacement of sand shall not have more than 12 percent loss on ignition when tested according to IS 1727.

IS 12894 : 2002

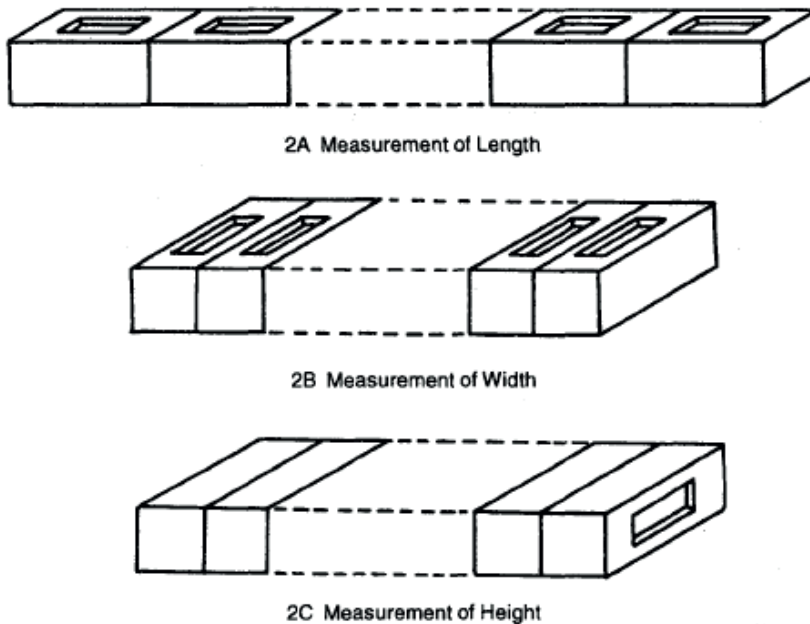

FIG. 2 MEASUREMENT OF TOLERANCES OF COMMON BUILDING BRICKS

### 6.3 Sand

Deleterious materials, such as clay and silt in sand, shall preferably be less than 5 percent.

### 6.4 Lime

Lime shall conform to Class C hydrated lime of IS 712.

### 6.5 Additives

Any suitable additive considered not detrimental to the durability of the bricks such as gypsum, cement, etc, may be used.

## 7 PHYSICAL CHARACTERISTICS

### 7.1 Compressive Strength

The minimum average wet compressive strength of pulverized fuel ash-lime bricks shall not be less than the one specified for each class in 4.1 when tested as described in IS 3495 ( Part 1 ). The wet compressive strength of any individual brick shall not fall below the minimum average wet compressive strength specified for the corresponding class of bricks by more than 20 percent.

NOTE — In case any of the test results of wet compressive strength exceed the upper limit for the class, the same shall be limited to the upper limit of the class for the purpose of averaging.

### 7.2 Drying Shrinkage

The average drying shrinkage of the bricks when tested by the method described in IS 4139, being the average

of three units, shall not exceed 0.15 percent.

### 7.3 Efflorescence Test

The bricks when tested in accordance with the procedure laid down in IS 3495 ( Part 3 ), shall have the rating of efflorescence not more than 'moderate' up to Class 12.5 and 'slight' for higher classes.

### 7.4 Water Absorption

The bricks, when tested in accordance with the procedure laid down in IS 3495 ( Part 2 ), after immersion in cold water for 24 h, shall have average water absorption not more than 20 percent by mass up to class 12.5 and 15 percent by mass for higher classes.

## 8 SAMPLING AND CRITERIA FOR CONFORMITY

8.1 Sampling and criteria for conformity of the bricks shall be as given in IS 5454.

## 9 MARKING

9.1 Each brick shall be marked in a suitable manner with the manufacturer's identification mark or initials.

### 9.2 BIS Certification Marking

The bricks may also be marked with the Standard Mark.

9.2.1 The use of the Standard Mark is governed by the provisions of the *Bureau of Indian Standards Act, 1986* and the Rules and Regulations made thereunder. The details of conditions under which the licence for the use of the Standard Mark may be granted to manufacturers or producers may be obtained from the Bureau of Indian Standards.

## Annexure 3: IS 2212: 1991 (Reaffirmed 2005)

IS 2212 : 1991

**Table 1 Selection of Building Bricks**  
( Clause 6.1.1 )

Sl No.	Situation of Use	Type of Bricks to be Used	Special Consideration	Remarks
(1)	(2)	(3)	(4)	(5)
1.	Facing	Class 12.5 common bricks ( see IS 1077 : 1991 )	Bricks shall be free from minor defects, such as chips at the edge of corners. Colour and texture may also be specified if so required	—
2.	a) Subject to very heavy loading	Heavy duty ( see IS 2180 : 1988 )	—	—
	b) Requiring a high resistance to water penetration	do	—	—
3.	a) Plinths and foundations below damp-proof course — ground well drained and no chance of continual wetting in foundations	Class 12.5 or Class 7.5 common bricks ( see IS 1077 : 1991 )	—	—
	b) Plinths and foundations below damp-proof course — subsoil water table at a high level	do	The bricks shall be free from efflorescence. They shall also not have any salt content which will affect the mortar of the masonry. The bricks may preferably be the densest available with the minimum water absorption	—
4.	a) External walls, neither plastered nor rendered on the outer face	Class 12.5 common bricks ( see IS 1077 : 1991 )	The bricks shall preferably be of uniform colour	The exposed joints shall be pointed with a dense water tight mortar
	b) External walls finished on both faces with a water-tight plaster or rendering	Class 7.5 or better quality common bricks ( see IS 1077 : 1991 )	—	For situations exposed to severe weather ( see Table 3 ) only Class 12.5 common bricks shall be used as in 4(a).
5.	Internal walls	Class 7.5 common bricks ( see IS 1077 : 1991 )	—	Class 3.5 common bricks also may be considered for use, provided they satisfy the requirements for strength ( see IS 1077 : 1991 ) For walls which are liable to be frequently in contact with water such as in bathrooms, only Class 7.5 or better bricks shall be used
6.	Free standing walls, parapets	Class 12.5 common bricks ( see IS 1077 : 1991 )	—	A dense water-tight mortar shall be used for the masonry. Parapets shall preferably be finished on all sides with a water-tight plaster

**Annexure 4: Details of the samples**

Code	Name	Area	Raw materials	Composition (per cent)	Per day production (bricks)
<b>HARYANA</b>					
1	JMC Project (Construction site)	Gurugram	Not applicable (NA)	NA	NA
2	Khanak Fly Ash Bricks	Gurugram	Pond ash or bottom ash	40	20,000
			Lime	35	
			Gypsum	10	
			Stone dust	15	
3	AIIMS (Construction site)	Jhajjar	NA	NA	NA
4	Shristi Fly Ash Bricks	Jhajjar	Pond ash	70	30,000
			Gypsum	12	
			Lime	18	
5	Laxmi Chand	Palra, Gurugram	Bottom ash	45	18,000–20,000
			Lime	22	
			Gypsum or plaster of Paris (POP) powder	20	
			Stone dust	13	
6	Balaji Enterprise	Palra, Gurugram	Pond ash	66	14,000–16,000
			Lime	23	
			Gypsum	11	
7	SR Bricks	Bhonsi- Sohna Road, Gurugram	Pond ash or bottom ash	58	32,000
			POP	13	
			Lime	16	
			Sand	13	
8	Centre for Innovative Building Material	Sohna Road, Gurugram	Fly ash	60	80,000
			Lime sludge	20	
			Gypsum or POP	10	
			Stone dust	10	
9	Shree Bricks	Panipat	Fly ash	65	15,000
			Lime	25	
			Gypsum	10	
10	Anttil Bricks	Sonipat	Pond ash	50	30,000
			Lime	20	
			Gypsum	15	
			Sand	15	

Code	Name	Area	Raw materials	Composition (per cent)	Per day production (bricks)
11	Om Construction	Sonipat	Bottom ash	62	20,000–25,000
			Lime	16	
			Gypsum	6	
			Stone dust	16	
12	Om Construction		Bottom ash	68	
			Cement	7	
			Gypsum	6	
			Stone dust	19	
13	MK Trading	Pond ash	72	60,000 with two shifts a day	
		Lime	20		
		Gypsum	5		
		Stone dust	3		
14	Raj Singh Brick Company	Pond ash	71	12,000	
		Lime	24		
		Gypsum	5		
15	Shree Balaji Bricks	Fly ash	55	30,000–32,000	
		Cement	15		
		Dust	30		
16	Meher Bricks	Pond or bottom ash	66	10,000–12,000	
		Gypsum	5		
		Lime	16		
		Dust	13		
17	JP Tading	Fly Ash	78	10,000–12,000	
		Gypsum	5		
		Lime	17		
<b>UTTAR PRADESH</b>					
18	Amit Ashtech	Fly ash	65	15,000	
		Bottom Ash	10		
		Lime	18		
		Gypsum	7		
19	Chaman Bricks	Pond ash or bottom ash	70	10,000	
		POP	5		
		Lime	25		
20	Mayur Bricks	Pond ash or bottom ash	75	12,000	
		Lime	18		
		Gypsum	7		

Code	Name	Area	Raw materials	Composition (per cent)	Per day production (bricks)
21	Ashtech	Dadri	Mixed ESP ash + bottom ash	71	1.2 lakh
			Cement	14	
			Coarse sand	15	
22	Stonex Infrastructure	Dadri	Pond or bottom ash	71	15,000
			Lime	18	
			Gypsum	7	
			Cement	4	
23	A.G. Bricolage	Greater Noida	Fly ash	74	15,000
			POP	8	
			Lime	18	
24	Antriksh Enterprises (Construction site & Inhouse Manufacturing Unit)	Greater Noida	Fly ash	52	13,000
			Bottom ash + pond ash	26	
			Sand	13	
			Cement (ordinary Portland cement)	8	
25	Miglani Groups (Construction Site)	Greater Noida (West)	NA	NA	NA
26	Deep Kamal Fly Ash	Greater Noida	ESP ash + pond ash or bottom ash	74	15,000
			Lime	21	
			Gypsum	5	
27	TSD Enterprise	Meerut	ESP ash + pond ash or bottom ash	38	50,000
			Cement	12	
			Stone dust	50	
28	TSD Enterprise		ESP ash + pond ash or bottom ash	40	
			Cement	12	
			Stone dust	48	
29	Rajeev Brick Field	Meerut	ESP ash (60 per cent) + bottom ash (40 per cent)	65	35,000
			Lime	25	
			Gypsum	10	
			Hardener	25 ml per 100 bricks	
30	Eternal Engineers	Meerut	ESP ash + Bottom ash	90	15,000
			Cement	10	
			Hardener	40 ml per 100 bricks	

Code	Name	Area	Raw materials	Composition (per cent)	Per day production (bricks)
31	Vishwakarma Enterprises	Meerut	Fly ash	70	15,000
			Lime	23	
			Gypsum	7	
32	R.S. Enterprise	Chapraula, Ghaziabad	Pond ash or bottom ash	61	10,000-12,000
			Lime	30	
			Gypsum	9	
33	New Company (Name not known)	Chapraula, Ghaziabad	Pond or bottom ash	78	15,000
			Sludge lime	16	
			Gypsum	6	
34	Power Bricks Corporation	Chapraula, Ghaziabad	Fly ash	50	20,000
			Lime	20	
			Gypsum	10	
			Stone dust	20	
35	Grey Brick Field	Chapraula, Ghaziabad	ESP ash	56	15,000
			Bottom ash	18	
			Lime	18	
			Gypsum	6	
36	Struglignce Bricks	Noida	Fly ash	37	35,000
			Bottom ash	37	
			Lime	13	
			Gypsum	5	
			Cement	3	
			Dust	4	
			Melamine chemical hardener	A few milli-litres	
37	D.P. Fly Ash Bricks	Greater Noida	Fly ash	65	42,000–45,000
			Dust	10	
			Gypsum	5	
			Sludge lime	20	
<b>DELHI</b>					
38	R.K Enterprise	Nangli Sakrawati	Pond ash or bottom ash	67	15,000
			Lime	22	
			Gypsum	11	
39	Daksh Enterprise	Nangli Sakrawati	Pond ash or bottom ash	67	20,000–25,000
			Lime	22	
			Gypsum	11	
40	Konastha Bricks	Nangli Sakrawati	Pond ash or bottom ash	68	10,000
			Lime	22	
			Gypsum	10	

Code	Name	Area	Raw materials	Composition (per cent)	Per day production (bricks)
41	Somi Bricks	Nangli Sakrawati	Pond ash or bottom ash	62	20,000
			Lime	28	
			Gypsum	10	
42	Harish Enterprises	Nangli Sakrawati	Pond ash or bottom ash	76	16,000
			Lime	17	
			Gypsum	7	
43	V.K. Enterprise	Nangli Sakrawati	Pond ash or bottom ash	64	15,000
			Lime	27	
			Gypsum	9	
44	Mann Bricks	Nangli Sakrawati	Pond ash or bottom ash	66	15,000
			Lime	23	
			Gypsum	11	
45	M.B. Bricks	Nangli Sakrawati	Pond ash or bottom ash	78	12,000
			Lime	16	
			Gypsum	6	
46	Surajbhan Bricks	Nangli Sakrawati	Pond ash or bottom ash	68	12,000
			Lime	22	
			Gypsum	10	
<b>RAJASTHAN</b>					
47	Mohini Bricks	Bhiwadi	Pond ash or bottom ash	74	10,000
			POP	6	
			Lime	20	
48	Rohan Traders	Bhiwadi	Pond ash or bottom ash	63	10,000
			Dust	23	
			Cement	14	
			Hardener (Malamine)	A few milli-litres	
49	M.K. Earthmovers	Bhiwadi	Fly ash	76	10,000
			Lime	13	
			Gypsum	7	
			Dust	4	
50	Haridev Traders	Bhiwadi	Pond ash or bottom ash	49	4,000
			Sludge lime	24	
			Gypsum	15	
			Dust	12	
51	Eco Bricks	Bhiwadi	Fly ash	69	15,000
			Lime	17	
			Gypsum	14	

Source: CSE survey

## References

1. Central Electricity Authority 2018. *Report on Fly Ash Generation at Coal/ Lignite Based Thermal Power Stations and Its Utilization in the Country for the Year 2017-18*. Ministry of Power, Government of India
2. A. Basumajumdar, A. K. Das, N. Bandyopadhyay & S. Maitra 2005. 'Some studies on the reaction between fly ash and lime'. *Bulletin of Materials Science*, 28(2), 131-136
3. A. K. Das, D. Ghosh, S. Maitra and A. Das 2015. 'Studies on the interaction of fly ash with lime in presence of varying quantity of sand'. *International Research Journal of Engineering and Technology*, Volume: 02 Issue: 09
4. Anon 2019. *FaL-G : The Technology for Superior Quality of Bricks and Blocks 2019*. Institute for Solid Waste Research & Ecological Balance (INSWAREB), Visakhapatnam
5. Anon 2019. 'Guidelines for manufacturing quality fly ash lime-gypsum/ cement bricks in fly ash bricks'. *Modern building material towards cleaner environment*. Chapter 7, page 15, NTPC Ltd, Government of India
6. A. K. Das, D. Ghosh, S. Maitra and A. Das 2015. 'Studies on the interaction of fly ash with lime in presence of varying quantity of sand'. *International Research Journal of Engineering and Technology*, Volume: 02 Issue: 09
7. Anon 2019. *Dos And Don'ts For Fal G Technology*, Institute for Solid Waste Research & Ecological Balance (INSWAREB), Vishakhapatnam
8. Anon 2019. 'Guidelines for manufacturing quality fly ash lime-gypsum/ cement bricks in fly ash bricks'. *Modern building material towards cleaner environment*, Chapter 7, page 15, NTPC Ltd, Government of India
9. S. Maity, K. Nagrath and D. Varsha 2016. *The Fly ash Brick Industry in Bihar: An Analysis*, Page No 19, Development Alternatives, New Delhi



Fly ash bricks have proved themselves a worthy alternative to clay-fired bricks, not least because they make use of fly ash, a 'waste' product from industries, particularly thermal power plants. The production of these bricks has picked up in Delhi-NCR in the last few years. Many different compositions are used to manufacture these bricks, but a Centre for Science and Environment survey found that they are missing a key ingredient, compromising their quality. What is that ingredient? Read this report to find more.



**Centre for Science and Environment**

41, Tughlakabad Institutional Area, New Delhi 110 062

**Phones:** 91-11-40616000 **Fax:** 91-11-29955879

**E-mail:** [cse@cseindia.org](mailto:cse@cseindia.org) **Website:** [www.cseindia.org](http://www.cseindia.org)